



MITSUBISHI ELECTRIC AUTOMATION (THAILAND) CO., LTD.
 Bang-Chan Industrial Estate No. 111 Moo 4, Serithai Rd., T.Kannayao, A.Kannayao, BKK 10230 Thailand
 Tel: (66) 2517-1326, (66) 2919-9873 Fax: (66) 2517-1328 URL: www.meath-co.com E-mail: support@meath.co.th
บริษัท มิทซูบิชิ อิเล็กทริก ออโตเมชัน (ประเทศไทย) จำกัด
 นิคมอุตสาหกรรมบางชัน เลขที่ 111 หมู่ 4 ถนนเสรีไทย แขวงคันนายาว เขตคันนายาว กทม. 10230
 โทรศัพท์: (66) 2517-1326, (66) 2919-9873 โทรสาร: (66) 2517-1328 URL: www.meath-co.com E-mail: support@meath.co.th

MOTOR SPECIFICATION SHEET

MODEL : SF-PR 5.5kW 4P
 USED FOR : 380V 50Hz
 MANUFACTURER : MITSUBISHI ELECTRIC CORPORATION

DESCRIPTION	DETAIL
PHASE	3
MODEL NAME	SF-PR
RATED OUTPUT	5.5 kW
POLE	4
CODE	MEATH CODE : 1MU00F-400550PRLT0
OUTLINE DRAWING NO.	BD26805-A
RATED VOLTAGE (V)	380
RATED FREQUENCY (Hz)	50
RATED CURRENT (A)	11.3
RATED SPEED (min ⁻¹)	1460
RATED EFFICIENCY	91.2%
EFFICIENCY CLASS	IE3
THERMAL CLASS	130 (B)
RATING	S1 (CONTINUOUS)
ENCLOSURE CONSTRUCTION	TOTALLY ENCLOSED FAN COOLED
DEGREES OF PROTECTION	IP44
METHOD OF COOLING	IC411
FRAME NO.	132S
WEIGHT (kg)	56
STANDARD	JIS C 4213, JEC-2137-2000
INSTALLATION	FOOT MOUNTED
ROTATION	CCW (VIEWED FROM SHAFT END)
BEARING	LOAD SIDE : 6308ZZ OPPOSITE SIDE : 6207ZZ
BEARING GREASE	UREA GREASE
NOISE (dB.A)*	56
VIBRATION	V10
CIRCUMSTANCE CONDITION	AMBIENT TEMPERATURE : -30 ~ +40°C AMBIENT HUMIDITY : 100% RH (NO CONDENSATION) ABOVE SEA LEVEL : 1000m OR BELOW ENVIRONMENT : NO CORROSIVE/EXPLOSIVE GAS, NO STEAM OR CONDENSATION, MINIMAL DUST.
COLOR	MUNSELL N7 (GRAY)
TERMINAL BOX	NO. OF LEAD WIRES : 6 SOURCE CONNECTION : TERMINAL BLOCK
SHAFT SWING	≤0.03mm
MATERIAL	FRAME : STEEL PLATE BRACKET : ALUMINIUM SHAFT : CARBON STEEL STATOR CORE : ELECTRICAL STEEL WIRE : ENAMELLED COPPER MAGNET WIRE ROTOR CORE : ELECTRICAL STEEL CONDUCTOR : ALUMINIUM TERMINAL BOX : STEEL PLATE PAINTING : ACRYLIC RESIN
PRODUCTION COUNTRY	JAPAN

*Value indicates representative value, not guaranteed value.

Specifications subject to change without notice.

SPECIFICATION SHEET NO.				
SS-M-2622-A				

TYPE SF-PR SUPER-LINE THREE PHASE INDUCTION MOTOR

OUT LINE
DIMENSION IN mm

INDOOR USE TYPE

TOTALLY ENCLOSED FAN COOLED
PROTECTION DEGREE IP44 , COOLING METHOD IC411
FRAME NO. 132S

CUSTOMER _____
USER _____
FOR _____
CUST'S ORDER NO. _____
QUANTITY _____ UNIT _____
MFG ORDER NO. _____

YOUR ORDER	kW·POLES	VOLT	HERTZ	MASS kg/UNIT	STYLE NO.
	5.5kW 4P	380V	50Hz	56	

IE Code-Rated Eff	
5.5kW 4P	IE3-91.2%

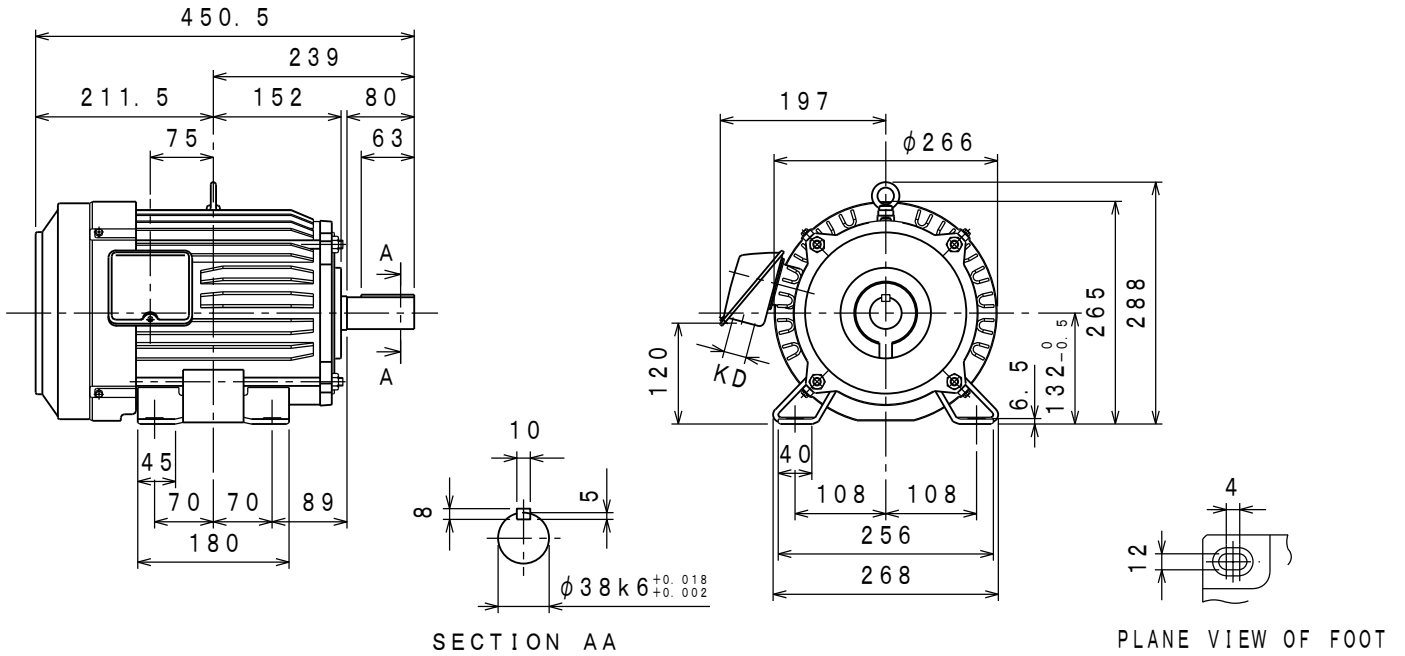

RATING	TH. CLASS	AMB. TEMP	BEARINGS		NO. OF TERMINALS	VIEWED FROM DRIVE END		COLOUR	KD
			LOAD SIDE	OPPOSITE SIDE		DIRECT. OF TERMINAL BOX	ROTATION		
S 1	130 (B)	40° C	6308ZZ	6207ZZ	6	A (LEFT)	CCW	MUNSELL N7	$\phi 27$

	DRAWN	APPROVED
SCALE NTS		
DATE		

(和文: BD26804)

MITSUBISHI ELECTRIC CORP., JAPAN
NAGOYA WORKS

改型	A	Aug. 10, '15	S. Suzuki, H. Ohba

図面
番号
DWG. **BD26805-A**
NO.

CAD(2D)