

**MOTOR SPECIFICATION SHEET**

MODEL : SF-PR 5.5kW 4P

USED FOR : 400V CLASS

MANUFACTURER : MITSUBISHI ELECTRIC AUTOMATION (THAILAND) CO.,LTD.

DESCRIPTION	DETAIL				
PHASE	3				
MODEL NAME	SF-PR				
RATED OUTPUT	5.5 kW				
POLE	4				
CODE	MEATH CODE : 1M002F-400550PRNG0				
OUTLINE DRAWING NO.	ONM24O632-B				
RATED VOLTAGE (V)	380	400	415	400	
RATED FREQUENCY (Hz)	50	50	50	60	
RATED CURRENT (A)	11.3	11.3	11.5	10.4	
RATED SPEED (min <sup>-1</sup> )	1460	1465	1465	1760	
RATED EFFICIENCY	91.2%	91.2%	90.9%	92.1%	
EFFICIENCY CLASS	IE3				
THERMAL CLASS	130 (B)				
RATING	S1 (CONTINUOUS)				
ENCLOSURE CONSTRUCTION	TOTALLY ENCLOSED FAN COOLED				
DEGREES OF PROTECTION	IP44				
METHOD OF COOLING	IC411				
FRAME NO.	132S				
WEIGHT (kg)	54				
STANDARD	JIS C 4213 / JEC-2110:2017				
INSTALLATION	FOOT MOUNTED				
ROTATION	CCW (VIEWED FROM SHAFT END)				
BEARING	LOAD SIDE : 6308ZZ				
	OPPOSITE SIDE : 6207ZZ				
BEARING GREASE	UREA GREASE				
NOISE (dB.A)*	50Hz : 56 / 60Hz : 61				
VIBRATION	V10				
CIRCUMSTANCE CONDITION	AMBIENT TEMPERATURE : -30 ~ +40°C				
	AMBIENT HUMIDITY : 100% RH (NO CONDENSATION)				
	ABOVE SEA LEVEL : 1000m OR BELOW				
	ENVIRONMENT : NO CORROSIVE/EXPLOSIVE GAS, NO STEAM OR CONDENSATION, MINIMAL DUST.				
COLOR	MUNSELL N7 (GRAY)				
TERMINAL BOX	NO. OF LEAD WIRES : 6				
	SOURCE CONNECTION : TERMINAL BLOCK				
SHAFT SWING	≤0.03mm				
MATERIAL	FRAME : STEEL PLATE				
	BRACKET : ALUMINIUM				
	SHAFT : CARBON STEEL				
	STATOR CORE : ELECTRICAL STEEL				
	WIRE : ENAMELLED COPPER MAGNET WIRE				
	ROTOR CORE : ELECTRICAL STEEL				
	CONDUCTOR : ALUMINIUM				
	TERMINAL BOX : STEEL PLATE				
PAINTING	PAINTING : ALKYD-NITROCELLULOSE RESIN				
PRODUCTION COUNTRY	THAILAND				

\*Value indicates representative value, not guaranteed value.

Specifications subject to change without notice.

SPECIFICATION SHEET NO.				
SS-N-2325-A				

MODEL SF-PR THREE PHASE INDUCTION MOTOR OUTLINE DRAWING

INDOOR MOTOR

TOTALLY ENCLOSED FAN COOLED TYPE  
DEGREES OF PROTECTION IP44

CUSTOMER \_\_\_\_\_  
USER \_\_\_\_\_  
FOR \_\_\_\_\_  
CUSTOMER'S ORDER NO. \_\_\_\_\_  
QUANTITY \_\_\_\_\_  
MFG. ORDER NO. \_\_\_\_\_

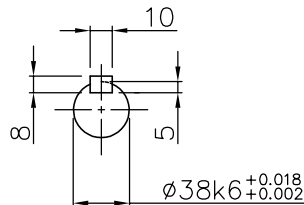
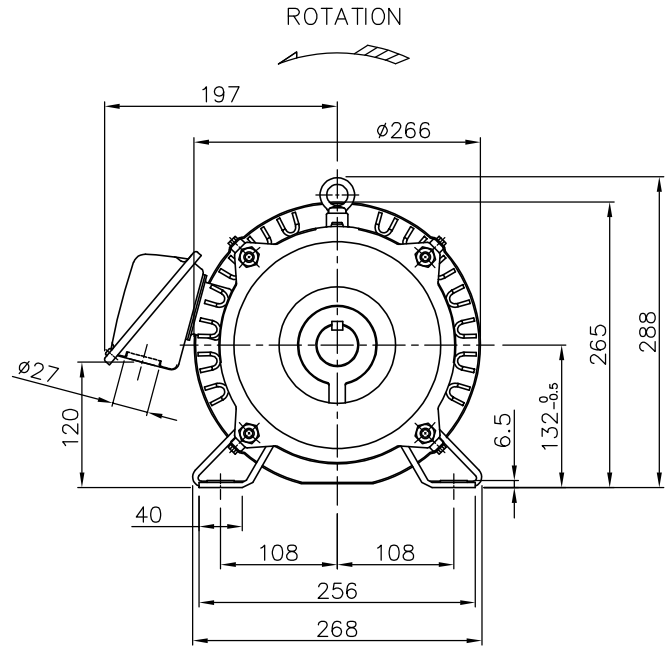
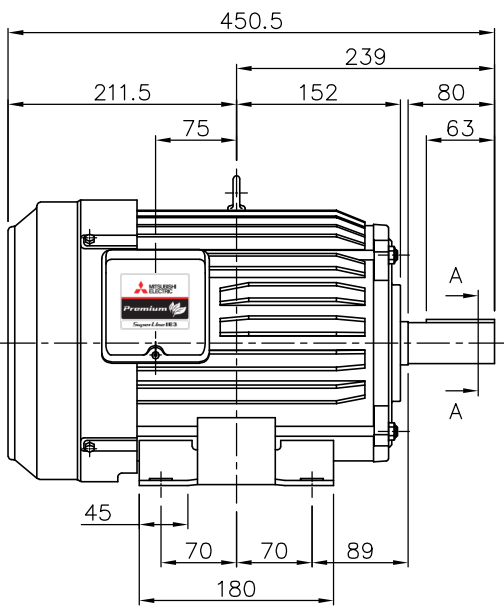

SECTION A-A

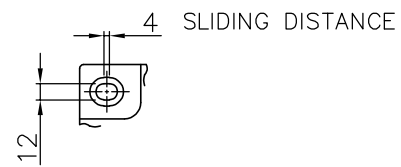

FRAME FOOT AS VIEWED FROM BELOW

FRAME SIZE	RATING	TH. CLASS	AMB. TEMP.	BEARINGS		COLOR	DIRECTION OF ROTATION (VIEWED FROM SHAFT END)	NO. OF TERMINALS	REMARKS
				LOAD SIDE	OPP. SIDE				
132S	S1 (CONT.)	130(B)	40°C	6308ZZ	6207ZZ	GRAY (MUNSELL N7)	CCW	6	

OUTPUT kW	POLE	RATE VOLTAGE	IE CODE-RATED EFF.				MASS(kg)
			50Hz		60Hz		
			380V	400V	415V	400V	
5.5	4	380/400/415V 50Hz 400V 60Hz	IE3-91.2%	IE3-91.2%	IE3-90.9%	IE3-92.1%	54

MITSUBISHI ELECTRIC AUTOMATION(THAILAND)CO.,LTD

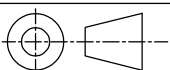

DIMENSION IN mm.  
SCALE : NTS

OUTLINE DRAWING NO.

0 N M 2 4 0 6 3 2

REV.

B