

**MOTOR SPECIFICATION SHEET**

MODEL : SF-QRGH 2HP 4P RATIO 1:10 (LT)

USED FOR : GEAR MOTOR

DESCRIPTION	DETAIL			
PHASE	3			
MODEL NAME	SF-QRGH			
RATED OUTPUT, HP (kW)	2 (1.5)			
POLE	4			
CODE	MEATH CODE : 1G7010-0150N-LTQR0			
OUTLINE DRAWING NO.	ONM94O342-A			
RATED VOLTAGE (V)	220	380	415	
RATED FREQUENCY (Hz)	50	50	50	
RATED CURRENT (A)	6.1	3.5	3.5	
RATED SPEED (min <sup>-1</sup> )	144	144	145	
RATED EFFICIENCY (%)	83.0	83.0	83.5	
EFFICIENCY CLASS	IE1			
THERMAL CLASS	155(F)			
RATING	S1 (CONTINUOUS)			
ENCLOSURE CONSTRUCTION	TOTALLY ENCLOSED FAN COOLED			
DEGREES OF PROTECTION	IP55			
METHOD OF COOLING	IC411			
FRAME NO.	90L			
WEIGHT (kg)	41			
STANDARD	IEC 60034-1, IEC 60034-30-1			
INSTALLATION	FOOT MOUNTED			
ROTATION	CCW (VIEWED FROM SHAFT END)			
BEARING	LOAD SIDE : 6305ZZ			
	OPPOSITE SIDE : 6204ZZ			
BEARING GREASE	UREA GREASE			
CIRCUMSTANCE CONDITION	AMBIENT TEMPERATURE : -20 ~ +40°C			
	AMBIENT HUMIDITY : 95%RH OR LESS			
	ABOVE SEA LEVEL : 1000m OR LESS			
	ENVIRONMENT : NO BURSTING/EROSIVE GAS OR VAPOR			
COLOR	MUNSELL N1.5 (BLACK)			
TERMINAL BOX	NO. OF LEAD WIRES : 6			
	SOURCE CONNECTION : TERMINAL BLOCK			
GEAR RATIO	1:10			
GEAR LUBRICANT	GREASE (Filled from factory.)			
SERVICE FACTOR	1.4			
MATERIAL	FRAME : STEEL PLATE			
	BRACKET (GEAR SIDE) : CAST IRON			
	BRACKET (OPP SIDE) : ALUMINIUM			
	GEAR CASE : CAST IRON			
	SHAFT (MOTOR) : STEEL			
	SHAFT (GEAR OUTPUT) : STEEL			
	STATOR CORE : ELECTRICAL STEEL			
	WIRE : ENAMELLED COPPER MAGNET WIRE			
	ROTOR CORE : ELECTRICAL STEEL			
	CONDUCTOR : ALUMINIUM			
	TERMINAL BOX : STEEL PLATE			
PAINTING : POLYURETHANE RESIN				
PRODUCTION COUNTRY	THAILAND			

Specifications subject to change without notice.

**SPECIFICATION SHEET NO.**

SS-M-9884-B

# MODEL SF-QRGH THREE PHASE INDUCTION MOTOR OUTLINE DRAWING

GEAR MOTOR

TOTALLY ENCLOSED FAN COOLED

DEGREES OF PROTECTION IP55

DUST & WATER JET PROOF

CUSTOMER

USER

FOR

CUSTOMER'S

ORDER NO.

QUANTITY

MFG.

ORDER NO.

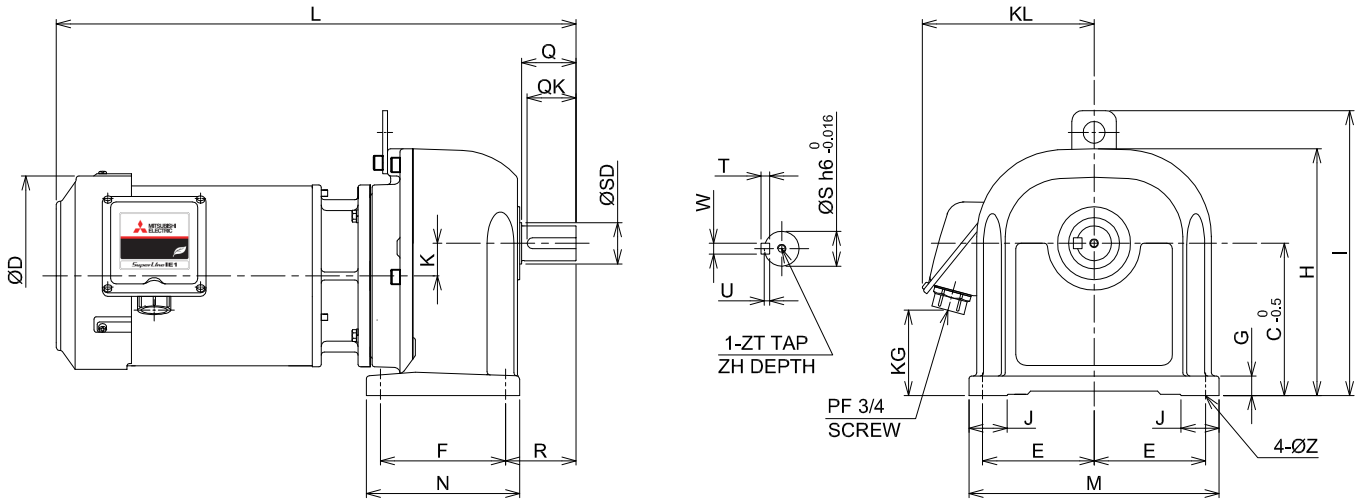

YOUR ORDER	GEAR RATIO	DIMENSION(mm.)																				WEIGHT (kg.)					
		L	Q	QK	ØD	K	F	R	N	T	W	U	ZT	ZH	ØS	ØSD	KL	KG	J	E	M		G	C	H	I	ØZ
	1:3~1:30	478	50	45	184	30	115	65	141	8	10	5	M8	12	32	34	158	78.4	35	102.5	230	18	140	227	262	12	41
	1:40,1:50	517.5	60	55	184	32	150	80	187	8	12	5	M8	12	40	45	158	81.4	45	107.5	250	22	145	230	265	15	53
	1:60	544	75	70	184	40	170	95	206	9	14	5.5	M8	12	48	50	158	98.4	50	125	285	22	170	275	310	15	67

YOUR ORDER	MOTOR FRAME SIZE	RATING	TH. CLASS	AMB. TEMP	BEARINGS		COLOR	GEAR RATIO	DIRECTION OF ROTATION (VIEWED FROM SHAFT END)	NO. OF LEAD WIRES	REMARKS
					LOAD SIDE	OPP. SIDE					
	90L	S1 (CONT.)	155(F)	40°C	6305ZZ	6204ZZ	BLACK (MUNSELL N1.5)	1:3~1:30	CCW	6	
								1:40~1:60	CW		

YOUR ORDER	RATIO	SERVICE FACTOR	MOTOR HP	OUTPUT kW	POLE	VOLT	HERTZ	OUTPUT SPEED (min <sup>-1</sup> )	AMP.	IE CODE - RATED EFF.	TYPE	LUBRICATION TYPE
	1:3	1.4	2	1.5	4	220/380/415	50	490/490/490	6.1/3.5/3.5	IE1-83.0%/83.0%/83.5%	LT	GREASE (1)
	1:5	1.4	2	1.5	4	220/380/415	50	290/290/290				
	1:10	1.4	2	1.5	4	220/380/415	50	144/144/145				
	1:15	1.4	2	1.5	4	220/380/415	50	96/96/97				
	1:20	1.4	2	1.5	4	220/380/415	50	71.5/71.5/72				
	1:25	1.4	2	1.5	4	220/380/415	50	60/60/60.5				
	1:30	1.4	2	1.5	4	220/380/415	50	49.5/49.5/50				
	1:40	1.4	2	1.5	4	220/380/415	50	34.5/34.5/35				
	1:50	1.4	2	1.5	4	220/380/415	50	31/31/31.5				
	1:60	1.4	2	1.5	4	220/380/415	50	25/25/25				

NOTE : (1) GREASE HAD BEEN FILLED FROM MANUFACTURER ALREADY.

MITSUBISHI ELECTRIC AUTOMATION (THAILAND) CO.,LTD.

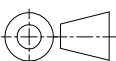

OUTLINE DRAWING NO.

REV.

DIMENSION IN mm.

SCALE : NTS

ONM940342

A