



MITSUBISHI ELECTRIC AUTOMATION (THAILAND) CO., LTD.

Bang-Chan Industrial Estate No. 111 Moo 4, Serithai Rd., T.Kannayao, A.Kannayao, BKK 10230 Thailand
 Tel: (66) 2517-1326, (66) 2919-9873 Fax: (66) 2517-1328 URL: www.meath-co.com E-mail: support@meath.co.th

บริษัท มิตซูบิชิ อิเล็กทริก ออโตเมชัน (ประเทศไทย) จำกัด

นิติบุคคลสหกรณ์บางชัน เลขที่ 111 หมู่ 4 ถนนเสรีไทย แขวงคันทนาเยาว เขตคันทนาเยาว กทม. 10230

โทรศัพท์: (66) 2517-1326, (66) 2919-9873 โทรสาร: (66) 2517-1328 URL: www.meath-co.com E-mail: support@meath.co.th

MOTOR SPECIFICATION SHEET

MODEL : SF-QRV 3HP 6P (LT)

USED FOR : STANDARD

DESCRIPTION	DETAIL			
PHASE	3			
MODEL NAME	SF-QRV			
RATED OUTPUT, HP (kW)	3 (2.2)			
POLE	6			
CODE	MEATH CODE : 1M002V-600220QVGD0			
OUTLINE DRAWING NO.	ONM140164-C			
RATED VOLTAGE (V)	220	380	415	
RATED FREQUENCY (Hz)	50	50	50	
RATED CURRENT (A)	9.7	5.6	5.4	
RATED SPEED (min ⁻¹)	940	940	950	
RATED EFFICIENCY (%)	77.7	77.7	79.0	
EFFICIENCY CLASS	IE1			
THERMAL CLASS	155(F)			
RATING	S1 (CONTINUOUS)			
ENCLOSURE CONSTRUCTION	TOTALLY ENCLOSED FAN COOLED			
DEGREES OF PROTECTION	IP55			
METHOD OF COOLING	IC411			
FRAME NO.	112M			
WEIGHT (kg)	41			
STANDARD	IEC 60034-1, IEC 60034-30-1			
INSTALLATION	FLANGE MOUNTED (VERTICAL)			
ROTATION	CCW (VIEWED FROM SHAFT END)			
BEARING	LOAD SIDE : 6207ZZ			
	OPPOSITE SIDE : 6206ZZ			
BEARING GREASE	UREA GREASE			
NOISE (db.A)	63			
VIBRATION	V10			
CIRCUMSTANCE CONDITION	AMBIENT TEMPERATURE : -20 ~ +40°C			
	AMBIENT HUMIDITY : 95%RH OR LESS			
	ABOVE SEA LEVEL : 1000m OR LESS			
	ENVIRONMENT : NO BURSTING/EROSIVE GAS OR VAPOR			
COLOR	MUNSELL N1.5 (BLACK)			
TERMINAL BOX	NO. OF LEAD WIRES : 6			
	SOURCE CONNECTION : TERMINAL BLOCK			
SHAFT SWING	≤0.03mm			
MATERIAL	FRAME : STEEL PLATE			
	BRACKET LOAD SIDE : CAST IRON (FLANGE)			
	OPPOSITE SIDE : ALUMINIUM			
	SHAFT : CARBON STEEL			
	STATOR CORE : ELECTRICAL STEEL			
	WIRE : ENAMELLED COPPER MAGNET WIRE			
	ROTOR CORE : ELECTRICAL STEEL			
	CONDUCTOR : ALUMINIUM			
	TERMINAL BOX : STEEL PLATE			
	PAINTING : POLYURETHANE RESIN			
PRODUCTION COUNTRY	THAILAND			

Specifications subject to change without notice.

SPECIFICATION SHEET NO.				
SS-M-1979-A				

MODEL SF-QRV THREE PHASE INDUCTION MOTOR OUTLINE DRAWING

TOTALLY ENCLOSED FAN COOLED TYPE
 DEGREES OF PROTECTION IP55
 DUST & WATER JET PROOF

CUSTOMER _____
 USER _____
 FOR _____
 CUSTOMER'S ORDER NO. _____
 QUANTITY _____
 MFG. ORDER NO. _____

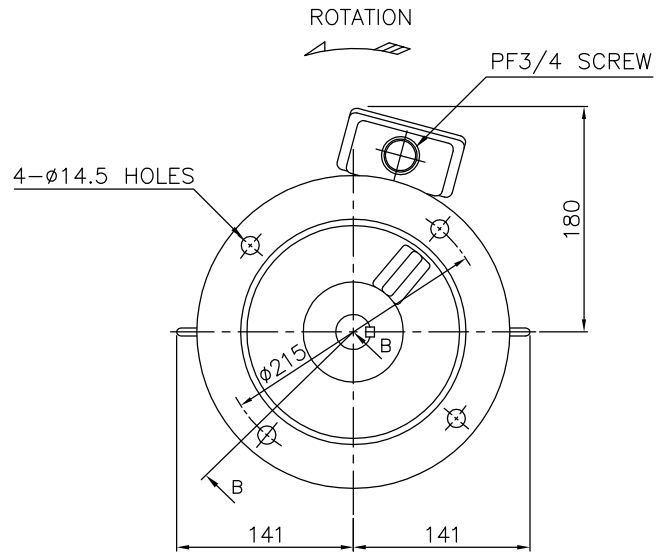
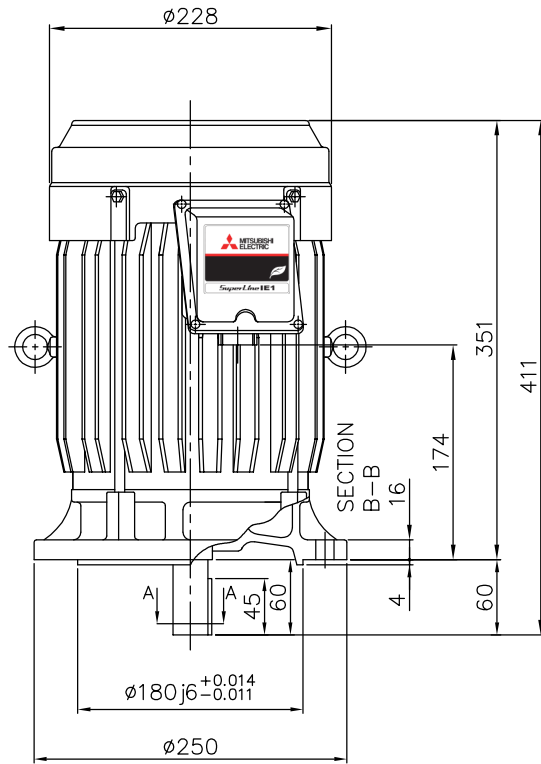

BOTTOM VIEW OF SHAFT END

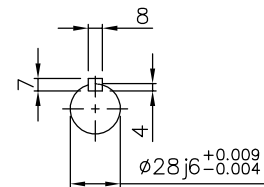

SECTION A-A

YOUR ORDER	FRAME SIZE	RATING	TH. CLASS	AMB. TEMP.	BEARINGS		COLOR	DIRECTION OF ROTATION (VIEWED FROM SHAFT END)	NO. OF LEAD WIRES	REMARKS
					LOAD SIDE	OPP. SIDE				
	112M	S1 (CONT.)	155(F)	40°C	6207ZZ	6206ZZ	BLACK (MUNSELL N1.5)	CCW	6	

YOUR ORDER	OUTPUT		POLES	VOLTS	HERTZ	AMP.	RPM	IE CODE-RATED EFF.	REMARKS
	HP	kW							
	5	3.7	2	220/380/415	50	12.8/7.4/7.0	2890/2890/2920	IE1 82.7%/82.7%/83.2%	LT
	5	3.7	4	220/380/415	50	14.0/8.1/8.0	1430/1430/1450	IE1 83.1%/83.1%/83.2%	LT
	3	2.2	6	220/380/415	50	9.7/5.6/5.4	940/940/950	IE1 77.7%/77.7%/79.0%	LT
	5	3.7	2	380/415	50	7.5/7.1	2890/2910	IE1 82.7%/83.2%	HT
	5	3.7	4	380/415	50	8.1/8.0	1440/1450	IE1 82.7%/82.7%	HT

MITSUBISHI ELECTRIC AUTOMATION (THAILAND) CO., LTD.

	OUTLINE DRAWING NO.	REV.	
	DIMENSION IN mm.	0 N M 1 4 0 1 6 4	C
	SCALE : NTS		