



TYPE
SX2

Technical Data

Electronic Meter SX2 Standard Model

Model Code	SX2-A30E
Standard	TIS 2543-2555, IEC 62052-11, IEC 62053-21
Display	LCD Display
Energy (kWh)	5 integer + 1 decimal
Display Item	kWh (import+export), Volt, Amp, kW
OPERATING CONDITION	
Power System	1-Phase 2-Wire
Reference Voltage	220-230 V
Operating Voltage	176-264 V
Rated Current	5(100) A
Reference Frequency	50 Hz
Temperature/Humidity	0-70 °C / 0-98 %RH (non-condensing)
ELECTRICAL CHARACTERISTICS	
Accuracy	Class 1
LCD Pulse	1500 imp/kWh
Power Consumption Voltage Circuit Current Circuit	< 2 W / 10 VA < 4 VA
Starting Current	20 mA (at reference voltage)
Over Current	120 A (continue for 30 minutes)
Surge Immunity	4 kV
Impulse Voltage	6 kV
MECHANICAL CONSTRUCTION	
Protective Class	Class II (double insulation)
Enclosure Protection	IP54 Weather proof
Applicable Conductors	25-50 mm ²
Mounting	3 points
Weight	0.66 kg

Model Code

SX2-A30E

Dimensions of Mounting Point (mm)

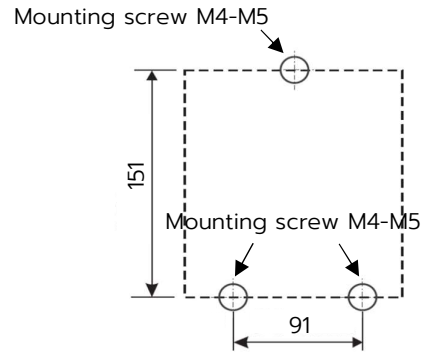

Dimensions (mm)

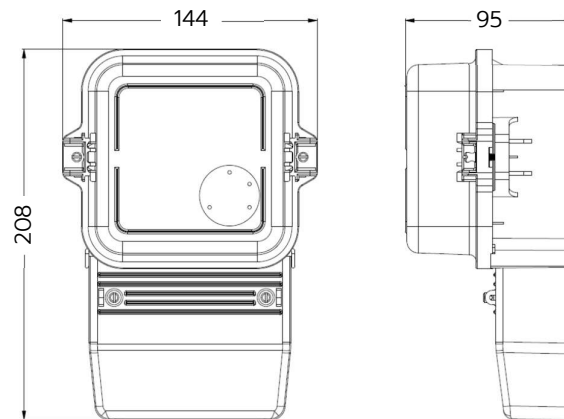

Connection Diagram

Connection Diagram

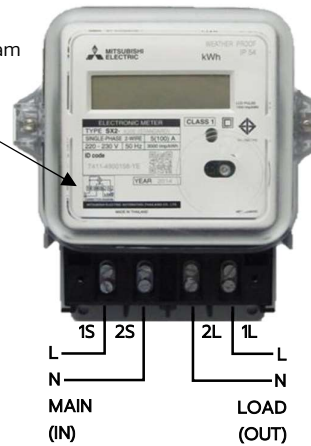
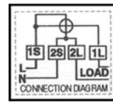

Specifications are subject to change without notice.

MITSUBISHI ELECTRIC AUTOMATION (THAILAND) CO., LTD.

Bang-Chan Industrial Estate No.111 Soi Serithai 54, T.Kannayao, A.Kannayao, Bangkok 10230, Thailand
Tel: (66)2517-1326, (66)2919-9873 URL: www.mitsubishi-meath.com/meter E-mail: meter_support@meath.co.th

MSD-U0031